

Zero-Order Energy Smart Antenna and Repeater

Researchers at the University of South Florida have invented the Zero-Order Energy antenna, which will automatically adapt its characteristics to its surroundings using a minimum energy approach.

Smart antennas are devices which adapt their radiation pattern to achieve improved performance. Current technologies of smart antennas are targeted towards systems that have moderate to large amount of computational and energy resources. These antennas are passive and have fixed performance. The antenna is targeted for wireless applications and have battery operated sensor nodes, where prime DC power is of major concern. Hence, there is a need for antennas which use lower transmission power, operate at greater communication distances and are self-optimizing.

USF researchers developed a novel invention: a device that will improve the radio link quality for low power wireless devices. The two smart ZOE antennas which will be configured for optimum signal reception at power up, then sampled and reconfigured at user defined time intervals. The repeater is used at a distance in order to boost the signal power and make it possible the increase range of communication. Zero-Order Energy Repeater (ZOE-R) is designed to optimize the configuration of the two ZOE antennas based on the signal strength of the repeater. The key feature of the invention is the reconfiguration of the antenna. The low duty cycle of the sampling and control circuit will ensure consumption of minimal DC energy.

ADVANTAGES:

- Improve the radio link quality
- Self-optimizing
- Operates with very low power
- Better communication range

Smart Antennas and Repeaters Using Minimal Power

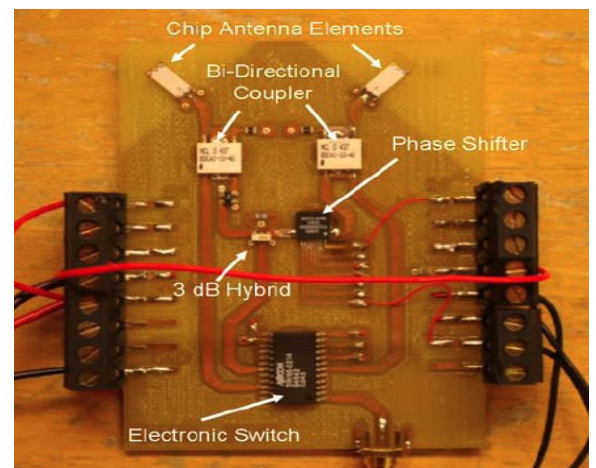

Zero Order Energy 2.4 GHz Antenna

Tech ID # 05B122

Patent #: [7,720,437](#)